



KAPPA-33/43/53 Medium Pressure Diaphragm Pump

KAPPA-33/43/53 3-cylinder, medium pressure diaphragm pumps are excellent choices for various horticulture, agricultural, lawn care, nursery, pest control and turf spraying applications. They are also effectively used in other applications such as aircraft de-icing, hydrostatic testing and cleaning. The KAPPA-33/43/53 pumps come standard with mounting rails and a 25mm solid keyed shaft.

KAPPA-33/43/53 pumps are constructed of anodized aluminum with anodized aluminum and stainless steel liquid handling parts. Control valve and pressure gauge are standard on all models.

Drive options include 5071.75 4-6.5 HP gear reduction.

For applications not listed, please consult UDOR U.S.A.

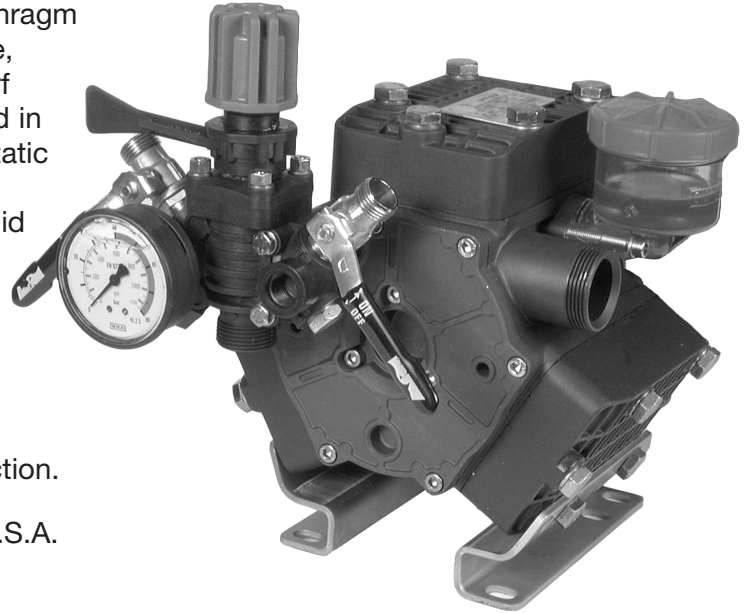

SPECIFICATIONS

Maximum Flow	
KAPPA-33	8.5 GPM
KAPPA-43	10.5 GPM
KAPPA-53	12.5 GPM
Maximum Pressure	560 PSI
Maximum RPM	540 RPM
Maximum Temperature	140° F
Inlet Port (Hose Barb) K-33 & 43	1"
* Inlet Port Hose Barb K-53	1-1/4"
Outlet Ports (Hose Barb, Ball Valve Controlled)	1/2" (2)
Bypass (Hose Barb)	3/4"
Dimensions	L-9.25" x W-11" x H-10"
Weight	29 lbs.
Diaphragm Material	
Standard	DESMOPAN
Optional	BUNA-N

NOTE - Protect pumps from freezing. If freezing conditions exist, flush pump and system with a 50/50 mixture of anti-freeze and water.

UDOR U.S.A., INC.

500 Apollo Drive
Lino Lakes, MN 55014
TEL. (651) 785-0666
FAX (800) 732-2670
www.udorusa.com

KAPPA-33/43/53 - Exploded View Diagram & Parts List

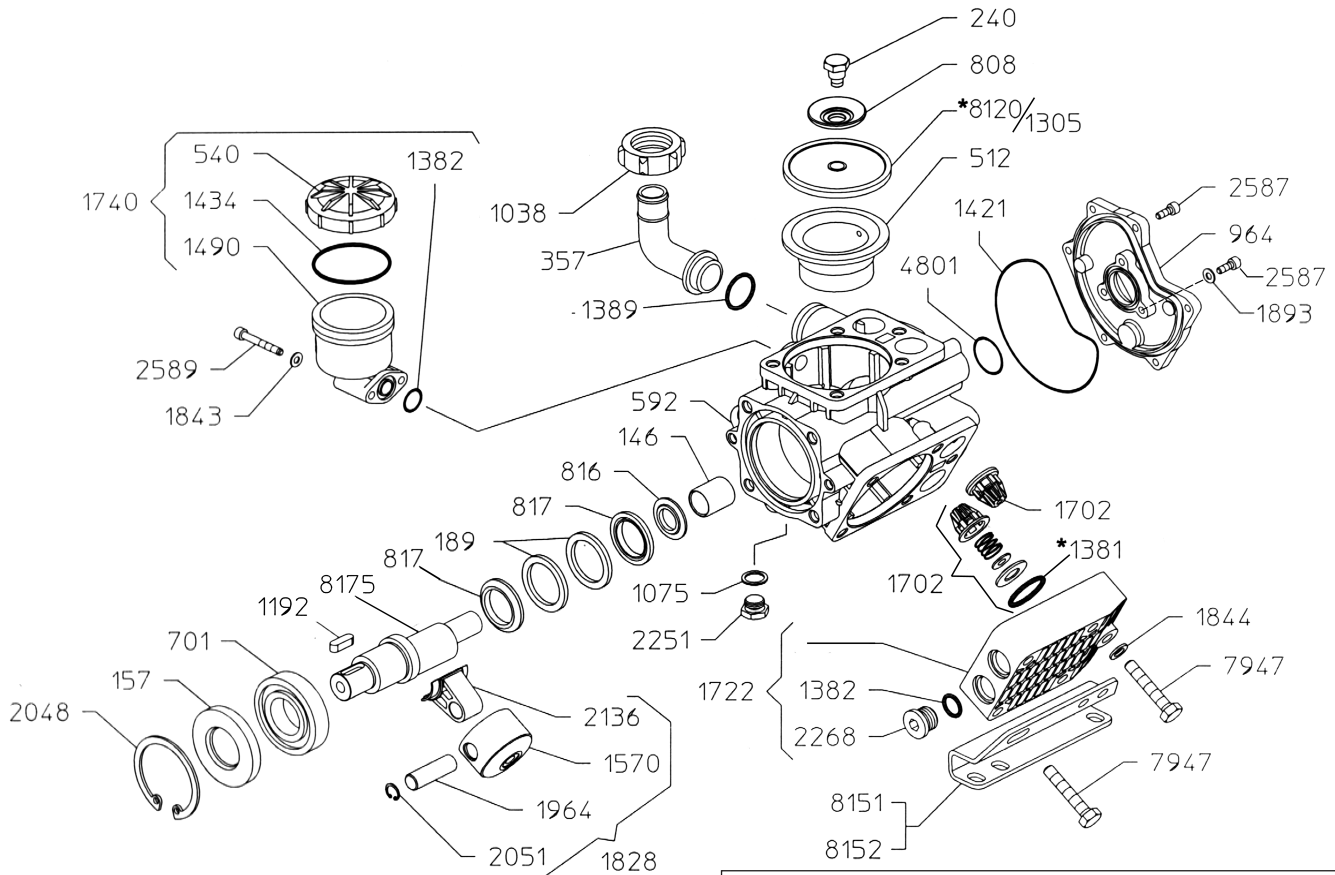

KAPPA-33/43/53 PUMPS

Require 20 oz.
UDOR LUBE
or SAE 30W
Non-detergent Oil

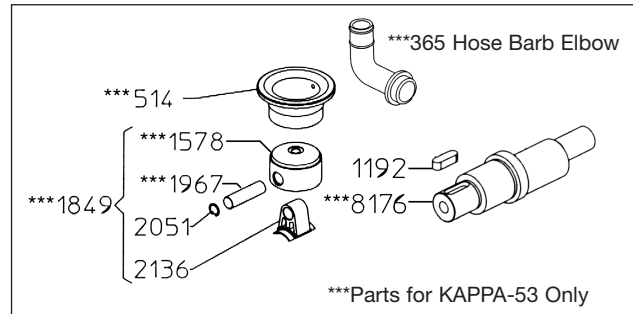
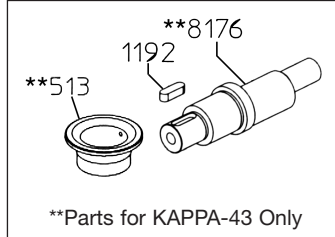

REF#	PART#	DESCRIPTION	QTY	REF#	PART#	DESCRIPTION	QTY
146	02-0006.14	Bearing	1	1740	02-6033.01	Oil Reservoir Assembly	1
157	02-0007.05	Seal	1	1828	02-6015.45	Piston & Rod Assembly (KAPPA-33/43)	3
189	02-0001.11	Retaining Ring	2	1843	02-1403.07	Washer	2
240	02-0102.04	Diaphragm Bolt	3	1844	02-1403.09	Washer	11
357	02-0202.18	Suction Elbow	1	***1849	02-6015.46	Piston & Rod Assembly (KAPPA-53)	3
***365	02-0202.52	Suction Elbow (KAPPA-53)	1	1893	02-1412.03	Washer	3
512	02-0206.42	Piston Sleeve (KAPPA-33)	3	1964	02-1502.03	Connecting Rod Pin (KAPPA-33/43)	3
513	02-0206.41	Piston Sleeve (KAPPA-43)	3	*1967	02-1502.07	Connecting Rod Pin (KAPPA-53)	3
***514	02-0206.43	Piston Sleeve (KAPPA-53)	3	2048	02-1506.07	Snap Ring	1
540	02-0208.98	Oil Reservoir Cap	1	2051	02-1506.15	Snap Ring	6
592	02-0209.73	Crankcase	1	2136	02-1519.28	Connecting Rod (KAPPA-33/43/53)	3
701	02-0214.05	Bearing	1	2251	02-1603.02	Plug	1
808	02-0301.43	Retaining Washer	3	2268	02-1603.32	Head Plug	6
816	02-0301.54	Spacer	1	2587	02-1805.20	Bolt	9
817	02-0302.66	Spacer	2	2589	02-1805.31	Bolt	2
964	02-0501.E2	Body Flange	1	4801	02-1101.C3	O-Ring	1
1038	02-0604.18	Barb Nut	1	7947	02-1804.21	Head Bolt	15
1075	02-0605.43	Gasket	1	*8120	02-0903.50	Piston Diaphragm (DESMOPAN)	3
1192	02-0801.02	Shaft Key	1	8151	02-1202.63	Mounting Rail - Right Side	1
1305	02-0903.43	Piston Diaphragm (BUNA-N) optional	3	8152	02-1202.64	Mounting Rail - Left Side	1
*1381	02-1101.27	O-Ring	6	8175	02-0002.B8	Crankshaft (KAPPA-33)	1
1382	02-1101.29	O-Ring	7	**8176	02-0002.B7	Crankshaft (KAPPA-43/53)	1
1389	02-1101.41	O-Ring	1				
1421	02-1101.88	O-Ring	1				
1434	02-1101.D1	O-Ring	1				
1490	02-1203.27	Oil Reservoir	1				
1570	02-1205.07	Piston (KAPPA-33/43)	3				
***1578	02-1205.18	Piston (KAPPA-53)	3				
1702	02-6006.01	Valve Assembly	6				
1722	02-6017.13	Head Assembly	3				

* Parts included in Diaphragm Repair Kit - Part #8700.45
Diaphragm Repair Kit also available in BUNA-N - Part #8700.46
** Parts for KAPPA-43 only.
*** Parts for KAPPA-53 only.