



High Volume Injection Metering Pump Unit

Models: IN-11610, IN-11630, IN-23510, IN-23530, IN-31310,
IN-47010, IN-47030

PARTS AND INSTRUCTION MANUAL



CDS-JOHN BLUE COMPANY

DIVISION OF ADVANCED SYSTEMS TECHNOLOGY, INC.

165 Electronics Blvd, Huntsville, AL 35824

Telephone: (256) 721-9090 - FAX: (256) 721-9091

Toll Free: 1-800-253-2583

TABLE OF CONTENTS

SAFETY PRECAUTIONS	3
WARNING.....	3
NOTE TO OWNER.....	3
INSTALLATION NOTES.....	4
ELECTRICAL INFORMATION.....	4
GEAR DRIVE MAINTENANCE.....	5
PUMP SETTING.....	6
SINGLE PHASE PARTS LIST	7
THREE PHASE PARTS LIST.....	8
OUTPUT CHARTS.....	9 – 13
WARRANTY	BACK COVER

SAFETY PRECAUTIONS

- Equipment should be operated only by responsible people.
- A careful operator is the best insurance against an accident.
- Fill system with WATER first and check output.
- Check all valves, fittings, hose clamps, etc. for wear / leaks before admitting process fluid to the system.
- Replace hoses when worn, cracked, or if leaking.

WARNING: USE OF THIS PRODUCT FOR ANY PURPOSES OTHER THAN ITS ORIGINAL INTENT, ABUSE OF THE PRODUCT, AND/OR MODIFICATION TO THE ORIGINAL PRODUCT IS STRICTLY PROHIBITED BY CDS-JOHN BLUE COMPANY. CDS-JOHN BLUE COMPANY RESERVES THE RIGHT TO DENY WARRANTY OR LIABILITY CLAIMS IN ANY/ALL SITUATIONS INVOLVING MISUSE, ABUSE OR MODIFICATION.

THE ORIGINAL INTENT OF THIS PRODUCT DOES NOT INCLUDE USE WHERE THE MAXIMUM ALLOWED SPEED, PRESSURE, OR TEMPERATURE IS EXCEEDED, AND IT DOES NOT INCLUDE APPLICATIONS UTILIZING FLUIDS THAT ARE NOT COMPATIBLE WITH THE PRODUCT'S COMPONENT MATERIALS. DO NOT USE THIS PRODUCT WITH FLAMMABLE OR COMBUSTIBLE FLUIDS SUCH AS GASOLINE, KEROSENE, DIESEL, ETC..., AND DO NOT USE IN EXPLOSIVE ATMOSPHERES. FAILURE TO FOLLOW THIS NOTICE MAY RESULT IN SERIOUS INJURY AND/OR PROPERTY DAMAGE AND WILL VOID THE PRODUCT WARRANTY. IF IN DOUBT ABOUT YOUR APPLICATION, CONTACT YOUR STOCKING DEALER OR THE CDS-JOHN BLUE TECHNICAL STAFF AT 1-800-253-2583.

To The Owner

This manual has been prepared and illustrated to assist you in the maintenance of your CDS – JOHN BLUE PUMP. Enter your serial number and the date of the purchase in the space provided below for future reference in service information or for ordering parts. Because our engineering department is constantly improving products, we reserve the right to make design and specification changes without notice.

Model Number: _____ Serial Number: _____ Purchase Date: _____

INSTALLATION NOTES

The irrigation injection metering pump units consist of a base with a motor and gear reduction unit, a low/high range reversible sprocket set, and a positive displacement variable stroke piston metering pump.

A typical installation is shown in figure 1 below. The pump used on these units is a CDS-John Blue positive displacement piston metering pump. This pump has a variable stroke piston that allows variation from 20% to 100% of full flow in each of the low range and high range configurations. It is capable of 120 psi under continuous operation, and 175 psi intermittent pressure. The pump also has positive cage-type suction and discharge valves, and does not require foot valves or special priming. Please note that a suction line strainer is recommended.

The pump is tested and calibrated at the factory, but it is suggested that a calibration check be performed after completion of the installation procedure to fine tune the system because variations in power and installation may affect the operation of your individual system. Please refer to the piston pump manual for all operation and maintenance instructions.

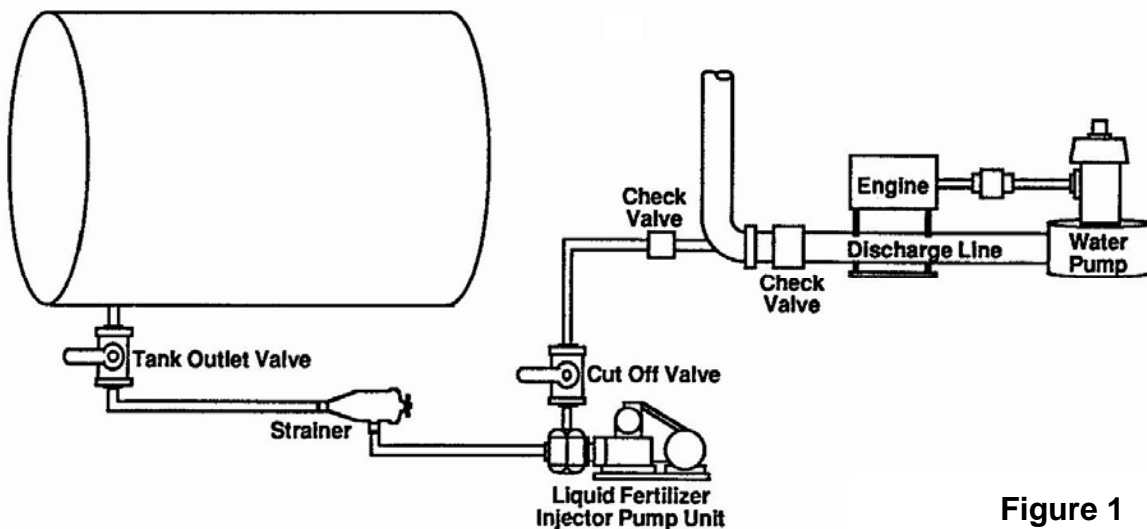

Figure 1

Electrical Information:

IN-11610, IN-23510, IN-31310, and IN-47010 units use a 1-1/2hp single phase 60 Hz motor:

Voltage: 110V / 208-230V FLA: 17.2A / 8.8 – 8.6A

IN-11610-50, IN-23510-50, and IN-31310-50 units use a 1-1/2hp single phase 50 Hz motor:

Voltage: 110V / 220V FLA: 17.2A / 8.2A

IN-11630, and IN-23530 units use a 3/4hp three phase motor:

Voltage: 380V / 460V FLA: 1.5A / 1.4A

IN-47030 units use a 1-1/2hp three phase motor:

Voltage: 380V / 460V FLA: 2.7A / 2.4A

Electrical Information (continued):

- A licensed electrician must be used to wire the pump/motor assembly. The wire and fuses should be sized by the licensed electrician based on the motor tag data and the length of wire run.
- Do not use the pump/motor assembly in explosive atmospheres – ensure adequate ventilation.
- Caution: Motor starters with properly sized thermal overload heaters are necessary for motor protection.

Note: The electric motors are warranted by the motor manufacturer. You can obtain prompt local service by consulting the manufacturer's authorized service center nearest you. CDS-John Blue can also assist you in obtaining this information. Please do not return any motors directly to CDS-John Blue, as this will only delay warranty service.

Gear Drive Maintenance Procedures

Units with **single** phase 50 and 60 Hz motors have a worm gear type reducer (shown in figure 2). This type of gear reducer uses 1.75 quarts of AGMA 7EP gear lube.

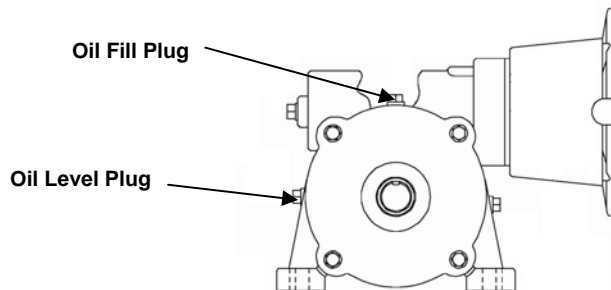

Figure 2

Units with **three** phase motors have a spur gear type reducer (shown in figure 3). This type of gear reducer uses 1.6 quarts of SAE 50W motor oil or EP 460 gear oil.

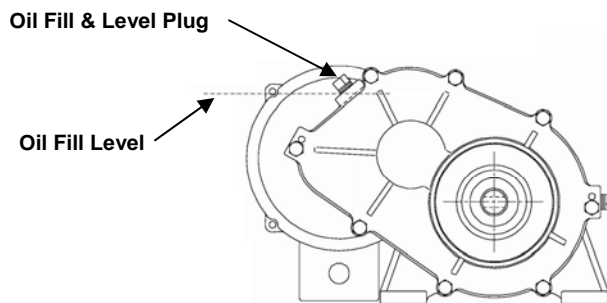

Figure 3

Both types of gear reducers should be inspected annually for the following:

- 1.) Check oil level, and check for contaminated/emulsified oil
- 2.) Check for excessive oil seal leaks
- 3.) That motor and junction box drain holes are clear

Note: Failure to maintain gearboxes will void the manufacturer's warranty.

Note: The gear reducers are warranted by the gear reducer manufacturer. You can obtain prompt local service by consulting the manufacturer's authorized service center nearest you. CDS-John Blue can also assist you in obtaining this information. Please do not return any gear reducers directly to CDS-John Blue, as this will only delay warranty service.

Pump Setting

The metering pump is driven by a set of RC-40 roller chain and sprockets. See the Output Charts at the end of this manual for your model pump to determine the desired:

- A.) the correct pump stroke setting
- B.) high or low range sprocket setting
- C.) duplex or simplex pump valve configuration

A.) Pump stroke setting

Read the desired pump setting from the output charts. Loosen the setting pointer nut and rotate the setting hub until the setting pointer is over the desired setting. The setting wrench will facilitate rotation of the setting hub. Once proper pump setting is achieved, tighten the setting pointer nut. Refer to the pump manual for more information.

B.) High or low range sprocket setting

See the figures below to determine sprocket location after you have chosen which range to use from the output charts.

Single Phase Units

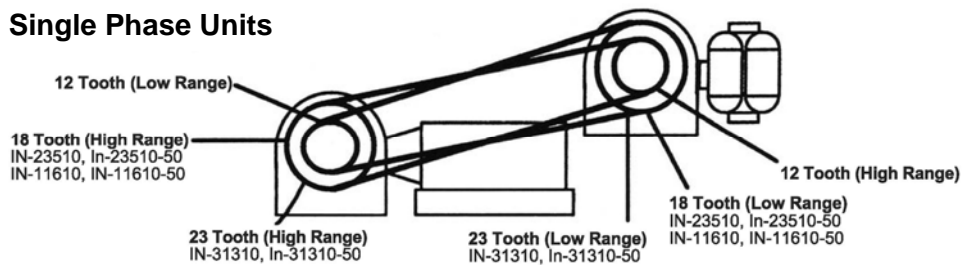

Three Phase Units

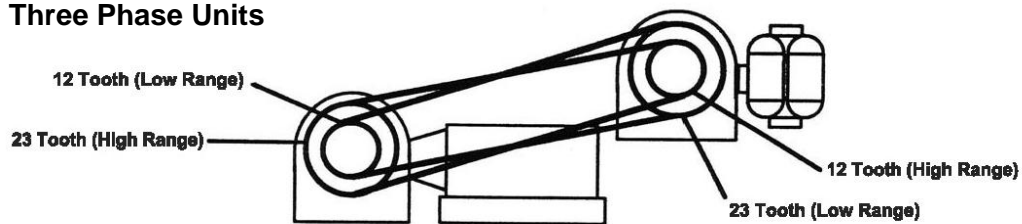

C.) Duplex or Simplex Valve configuration

The pump is supplied from the factory in the Duplex configuration, which means that fluid is being pumped as the piston travels in both directions. For simplex operation, the **suction** valve closest to the pump crankcase is replaced with the “blank valve plug”. This allows fluid to only be pumped as the piston travels in one direction.

Note that the two suction valves are located on the side of the manifolds closest to the inlet of the pump.

Single Phase Parts List

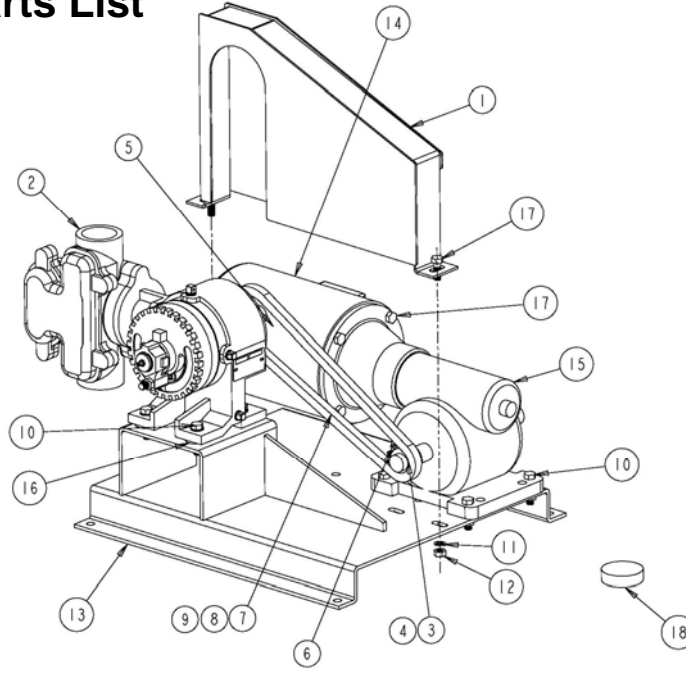

Item	IN-23510 *	IN-23510-50	IN-31310	IN-31310-50	IN-47010	IN-11610	IN-11610-50	Description	Qty
1	114364-01	114364-01	114364-01	114364-01	114364-01	114364-01	114364-01	Chain Guard	1
2	NGP-6055-K *	NGP-6055-K	NGP-6055-K	NGP-6055-K	NGP-6055-K	NGP-4055-KF	NGP-4055-KF	Pump (Check ID tag for model)	1
3	L-1020	L-1020	L-1020	L-1020	L-1020	L-1020	L-1020	Sprocket Key	2
4	90532	90532	90532	90532	90532	90532	90532	Sprocket Set Screw	4
5	113905-01 (18 tooth)	113905-01 (18 tooth)	114517-01 (23 tooth)	114517-01 (23 tooth)	113905-01 (18 tooth)	113905-01 (18 tooth)	113905-01 (18 tooth)	Large Sprocket	1
6	114516-01 (12 tooth)	114516-01 (12 tooth)	114516-01 (12 tooth)	114516-01 (12 tooth)	114516-01 (12 tooth)	114516-01 (12 tooth)	114516-01 (12 tooth)	Small Sprocket	1
7	A-5727	A-5727	A-5727	A-5727	A-5727	A-5727	A-5727	Chain - RC40	2.5 Ft.
8	S-2943	S-2943	S-2943	S-2943	S-2943	S-2943	S-2943	Connector Link	1
9	S-2944	S-2944	S-2944	S-2944	S-2944	S-2944	S-2944	Offset Link	1
10	90655	90655	90655	90655	90655	90655	90655	Bolt 3/8 x 1-1/2 lg.	8
11	93024	93024	93024	93024	93024	93024	93024	3/8 Lock Washer	10
12	92024	92024	92024	92024	92024	92024	92024	3/8 Nut	10
13	114354-91	114354-91	114354-91	114354-91	114354-91	114354-91	114354-91	Base	1
14	114515-01	115188-01	114515-01	115188-01	114515-01	114515-01	115188-01	Motor - Single Phase	1
15	114513-01 (30:1)	114513-01 (30:1)	114513-01 (30:1)	114513-01 (30:1)	114597-01 (20:1) 114598-01 (adapters)	114513-01 (30:1)	114513-01 (30:1)	Gearbox	1
16	A-147	A-147	A-147	A-147	A-147	A-147	A-147	Mounting Pad	4
17	90651	90651	90651	90651	90651	90651	90651	Bolt 3/8 x 1 lg.	6
18	114532-01	114532-01	114532-01	114532-01	114532-01	L-925	L-925	Blank Pump valve	1

* This unit optionally available with stainless wet-end, and also with fumigant seals ("S" and "US" suffix respectively.)

Three Phase Parts List

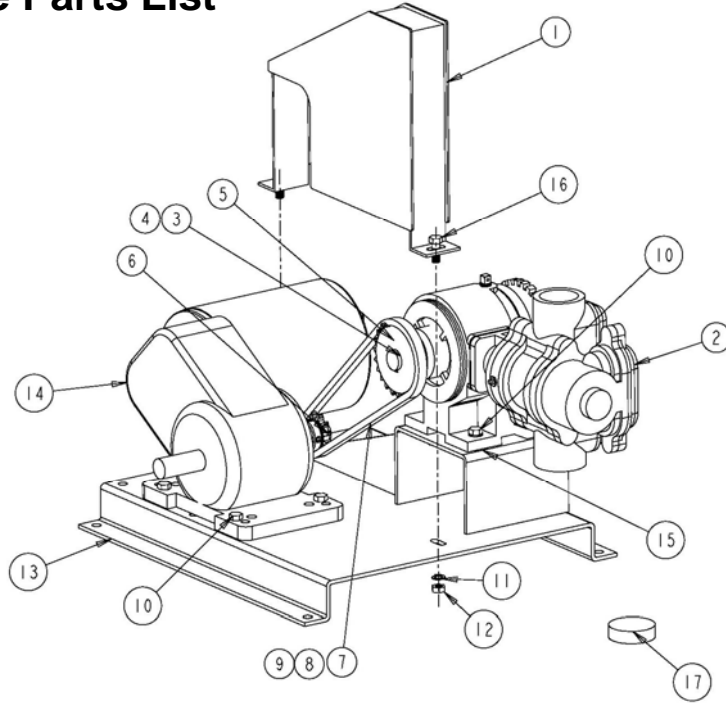

Item	IN-23530 *	IN-47030 **	IN-11630	Description	Qty
1	114360-01	114360-01	114360-01	Chain Guard	1
2	NGP-6055-K *	NGP-6055-K **	NGP-4055-KF	Pump (Check ID tag for model)	1
3	L-1020	L-1020	L-1020	Sprocket Key	2
4	90532	90532	90532	Sprocket Set Screw	4
5	114517-01 (23 tooth)	114517-01 (23 tooth)	114517-01 (23 tooth)	Large Sprocket	1
6	114516-01 (12 tooth)	114516-01 (12 tooth)	114516-01 (12 tooth)	Small Sprocket	1
7	A-5727	A-5727	A-5727	Chain - RC40	2.5 Ft.
8	S-2943	S-2943	S-2943	Connector Link	1
9	S-2944	S-2944	S-2944	Offset Link	1
10	90655	90655	90655	Bolt 3/8 x 1-1/2 lg.	8
11	93024	93024	93024	3/8 Lock Washer	10
12	92024	92024	92024	3/8 Nut	10
13	114354-91	114354-91	114354-91	Base	1
14	114514-01 (40:1)	115165-01 (20:1)	114514-01 (40:1)	3Ph Motor and Gearbox Assembly	1
15	A-147	A-147	A-147	Mounting Pad	4
16	90651	90651	90651	Bolt 3/8 x 1 lg.	2
17	114532-01	114532-01	L-925	Blank Pump valve	1

* This unit optionally available with stainless wet-end, and also with fumigant seals ("S" and "US" suffix respectively.)

** This unit optionally available with stainless wet-end ("S" suffix)

Output Chart for IN-11610 Injection Pump

	Gallons Per Hour			
	Low Range		High Range	
Pump Setting	Simplex (1 Valve)	Duplex (2 Valves)	Simplex (1 Valve)	Duplex (2 Valves)
2	5.3	10.5	11.9	23.5
2 ½	6.6	13.1	14.8	29.4
3	8.0	15.7	17.8	35.2
3 ½	9.3	18.3	20.8	41.1
4	10.6	21.0	23.8	47.0
4 ½	11.9	23.6	26.7	52.8
5	13.2	26.2	29.7	58.7
5 ½	14.6	28.8	32.7	64.6
6	15.9	31.4	35.7	70.5
6 ½	17.2	34.1	38.6	76.3
7	18.6	36.7	41.6	82.2
7 ½	19.9	39.3	44.5	88.1
8	21.2	41.9	47.5	93.9
8 ½	22.6	44.5	50.5	99.8
9	23.9	47.2	53.5	105.7
9 ½	25.2	49.8	56.4	111.5
10	26.5	52.4	59.4	117.4

Output Chart for IN-11610-50 Injection Pump

	Gallons Per Hour			
	Low Range		High Range	
Pump Setting	Simplex (1 Valve)	Duplex (2 Valves)	Simplex (1 Valve)	Duplex (2 Valves)
2	4.4	8.7	9.9	19.6
2 ½	5.5	10.9	12.4	24.5
3	6.6	13.1	14.8	29.4
3 ½	7.7	15.3	17.3	34.2
4	8.9	17.5	19.8	39.1
4 ½	9.9	19.7	22.3	44.0
5	11.0	21.8	24.7	48.9
5 ½	12.2	24.0	27.2	53.8
6	13.3	26.2	29.7	58.7
6 ½	14.4	28.4	32.2	63.6
7	15.5	30.6	34.7	68.5
7 ½	16.6	32.8	37.1	73.4
8	17.7	34.9	39.6	78.3
8 ½	18.8	37.1	42.1	83.2
9	19.9	39.3	44.6	88.1
9 ½	21.0	41.5	47.0	93.0
10	22.1	43.7	49.5	97.8

Output Chart for IN-11630 Injection Pump

	Gallons Per Hour			
	Low Range		High Range	
	Pump Setting	Simplex (1 Valve)	Duplex (2 Valves)	Simplex (1 Valve)
2	3.2	6.2	11.5	22.8
2 ½	3.9	7.8	14.5	28.5
3	4.7	9.3	17.3	34.2
3 ½	5.5	10.9	20.2	39.9
4	6.3	12.4	23.1	45.6
4 ½	7.1	14.0	26.0	51.3
5	7.9	15.5	28.9	57.1
5 ½	8.6	17.1	31.7	62.7
6	9.4	18.6	34.6	68.5
6 ½	10.2	20.2	37.5	74.1
7	11.0	21.7	40.4	79.9
7 ½	11.8	23.3	43.3	85.5
8	12.6	24.8	46.2	91.3
8 ½	13.3	26.4	49.1	96.9
9	14.1	27.9	52.0	102.7
9 ½	14.9	29.5	54.8	108.3
10	15.7	31.1	57.7	114.1

Output Chart for IN-23510 Injection Pump

	Gallons Per Hour			
	Low Range		High Range	
	Pump Setting	Simplex (1 Valve)	Duplex (2 Valves)	Simplex (1 Valve)
2	10.9	21.6	24.5	48.4
2 ½	13.7	27.0	30.6	60.5
3	16.4	32.4	36.7	72.6
3 ½	19.1	37.8	42.9	84.7
4	21.9	43.2	49.0	96.8
4 ½	24.6	48.6	55.1	108.9
5	27.3	54.0	61.2	121.0
5 ½	30.1	59.4	67.3	133.1
6	32.8	64.8	73.5	145.2
6 ½	35.5	70.2	79.6	157.3
7	38.3	75.6	85.7	169.4
7 ½	41.0	81.0	91.8	181.5
8	43.7	86.4	98.0	193.6
8 ½	46.5	91.8	104.1	205.7
9	49.2	97.2	110.2	217.8
9 ½	51.9	102.6	116.3	229.9
10	54.6	108.0	122.5	242.0

Output Chart for IN-23510-50 Injection Pump

	Gallons Per Hour			
	Low Range		High Range	
	Pump Setting	Simplex (1 Valve)	Duplex (2 Valves)	Simplex (1 Valve)
2	9.1	18.0	20.4	40.3
2 ½	11.4	22.5	25.5	50.4
3	13.7	27.0	30.6	60.5
3 ½	15.9	31.5	35.8	70.6
4	18.3	36.0	40.8	80.7
4 ½	20.5	40.5	45.9	90.8
5	22.8	45.0	51.0	100.8
5 ½	25.1	49.5	56.1	110.9
6	27.3	54.0	61.3	121.0
6 ½	29.6	58.5	66.3	131.1
7	31.9	63.0	71.4	141.2
7 ½	34.2	67.5	76.5	151.3
8	36.4	72.0	81.7	161.3
8 ½	38.8	76.5	86.8	171.4
9	41.0	81.0	91.8	181.5
9 ½	43.3	85.5	96.9	191.6
10	45.5	90.0	102.1	201.7

Output Chart for IN-23530 Injection Pump

	Gallons Per Hour			
	Low Range		High Range	
	Pump Setting	Simplex (1 Valve)	Duplex (2 Valves)	Simplex (1 Valve)
2	6.5	12.8	23.8	47.0
2 ½	8.1	16.0	29.8	58.8
3	9.7	19.2	35.7	70.5
3 ½	11.3	22.4	41.6	82.3
4	13.0	25.6	47.6	94.0
4 ½	14.6	28.8	53.5	105.8
5	16.2	32.0	59.5	117.6
5 ½	17.8	35.2	65.4	129.3
6	19.4	38.4	71.4	141.1
6 ½	21.0	41.6	77.3	152.8
7	22.7	44.8	83.3	164.6
7 ½	24.3	48.0	89.2	176.3
8	25.9	51.2	95.2	188.1
8 ½	27.5	54.4	101.1	199.8
9	29.1	57.6	107.1	211.6
9 ½	30.8	60.8	113.0	223.3
10	32.4	64.0	119.0	235.1

Output Chart for IN-31310 Injection Pump

	Gallons Per Hour			
	Low Range		High Range	
	Pump Setting	Simplex (1 Valve)	Duplex (2 Valves)	Simplex (1 Valve)
2	8.5	16.9	31.3	61.8
2 ½	10.7	21.1	39.1	77.3
3	12.8	25.4	46.9	92.8
3 ½	14.9	29.6	54.8	108.2
4	17.1	33.8	62.6	123.7
4 ½	19.3	38.0	70.4	139.2
5	21.4	42.3	78.2	154.6
5 ½	23.6	46.5	86.0	170.1
6	25.7	50.7	93.9	185.5
6 ½	27.8	54.9	101.7	201.0
7	30.0	59.2	109.5	216.5
7 ½	32.1	63.4	117.3	231.9
8	34.2	67.6	125.2	247.4
8 ½	36.4	71.8	133.0	262.8
9	38.5	76.1	140.8	278.3
9 ½	40.6	80.3	148.6	293.8
10	42.7	84.5	156.5	309.2

Output Chart for IN-31310-50 Injection Pump

	Gallons Per Hour			
	Low Range		High Range	
	Pump Setting	Simplex (1 Valve)	Duplex (2 Valves)	Simplex (1 Valve)
2	7.1	14.1	26.1	51.5
2 ½	8.9	17.6	32.6	64.4
3	10.7	21.1	39.1	77.3
3 ½	12.5	24.7	45.7	90.2
4	14.3	28.2	52.2	103.1
4 ½	16.0	31.7	58.7	116.0
5	17.8	35.2	65.2	128.8
5 ½	19.6	38.7	71.7	141.7
6	21.4	42.3	78.3	154.6
6 ½	23.2	45.8	84.8	167.5
7	25.0	49.3	91.3	180.4
7 ½	26.7	52.8	97.8	193.3
8	28.5	56.3	104.4	206.1
8 ½	30.3	59.9	110.8	219.0
9	32.1	63.4	117.3	231.9
9 ½	33.8	66.9	123.8	244.8
10	35.6	70.4	130.4	257.7

Output Chart for IN-47010 Injection Pump

	Gallons Per Hour			
	Low Range		High Range	
	Pump Setting	Simplex (1 Valve)	Duplex (2 Valves)	Simplex (1 Valve)
2	16.4	32.4	36.8	72.6
2 ½	20.6	40.5	45.9	90.8
3	24.6	48.6	55.1	108.9
3 ½	28.7	56.7	64.4	127.1
4	32.9	64.8	73.5	145.2
4 ½	36.9	72.9	82.7	163.4
5	41.0	81.0	91.8	181.5
5 ½	45.2	89.1	101.0	199.7
6	49.2	97.2	110.3	217.8
6 ½	53.3	105.3	119.4	236.0
7	57.5	113.4	128.6	254.1
7 ½	61.5	121.5	137.7	272.3
8	65.6	129.6	147.0	290.4
8 ½	69.8	137.7	156.2	308.6
9	73.8	145.8	165.3	326.7
9 ½	77.9	153.9	174.5	344.9
10	81.9	162.0	183.8	363.0

Output Chart for IN-47030 Injection Pump

	Gallons Per Hour			
	Low Range		High Range	
	Pump Setting	Simplex (1 Valve)	Duplex (2 Valves)	Simplex (1 Valve)
2	13.0	25.6	47.6	94.0
2 ½	16.2	32.0	59.6	117.6
3	19.4	38.4	71.4	141.0
3 ½	22.6	44.8	83.2	164.6
4	26.0	51.2	95.2	188.0
4 ½	29.2	57.6	107.0	211.6
5	32.4	64.0	119.0	235.2
5 ½	35.6	70.4	130.8	258.6
6	38.8	76.8	142.8	282.2
6 ½	42.0	83.2	154.6	305.6
7	45.4	89.6	166.6	329.2
7 ½	48.6	96.0	178.4	352.6
8	51.8	102.4	190.4	376.2
8 ½	55.0	108.8	202.2	399.6
9	58.2	115.2	214.2	423.2
9 ½	61.6	121.6	226.0	446.6
10	64.8	128.0	238.0	470.2

Notes

Notes

LIMITED WARRANTY

THIS WARRANTY IS IN LIEU OF ALL OTHER WRITTEN OR EXPRESS WARRANTIES AND REPRESENTATIONS. ANY IMPLIED WARRANTIES INCLUDING MERCHANTABILITY OR FITNESS FOR ANY PARTICULAR PURPOSE ARE EXPRESSLY LIMITED TO THIS WRITTEN WARRANTY. CDS-JOHN BLUE COMPANY SHALL NOT BE LIABLE FOR CONSEQUENTIAL DAMAGES.

Use of this product for any purpose other than its original intent, abuse of the product, and/or any modification to the original product is strictly prohibited by the manufacturer, CDS-John Blue Company. Any modification to the product should be approved by CDS-John Blue Company prior to use. CDS-John Blue Company will deny Warranty claims and liability in any situation involving misuse, abuse or modification.

Each new machine or component manufactured by CDS-John Blue Company through original buyer is warranted by CDS-John Blue Company to buyer and to any party or parties to whom buyer may resell, lease or lend the equipment to be free from defects in material and workmanship under normal use and service. This obligation of CDS-John Blue Company under this warranty is limited to the repair or replacement of defective parts or correction of improper workmanship of any parts of such equipment which shall within one year from the date of CDS-John Blue's original delivery thereof, be returned to CDS-John Blue's factory, transportation charges prepaid and which CDS-John Blue Company shall determine to its satisfaction upon examination thereof to have been thus defective. When it is impractical to return the defective parts of such equipment to CDS-John Blue's factory, then CDS-John Blue shall have no liability for the labor cost involved in repairing or replacing any such parts and shall be liable solely for supplying the material necessary to replace or repair the defective parts, provided that prior thereto CDS-John Blue Company shall have determined to its satisfaction that any such parts are thus defective.

This warranty shall not apply to any equipment which shall have been repaired or altered outside CDS-John Blue's factory in any way so as to affect its durability, nor which has been subjected to misuse, abuse, negligence or accident, or operated in any manner other than in accordance with operating instructions provided by CDS-John Blue Company. This warranty does not extend to repairs made necessary by the use of inferior or unsuitable parts or accessories, or parts or accessories not recommended by CDS-John Blue Company.

CDS-John Blue Company makes no warranties in respect to parts, accessories or components not manufactured by CDS-John Blue Company, same ordinarily being warranted separately by their respective manufacturers.

DIVISION OF ADVANCED SYSTEMS TECHNOLOGIES HUNTSVILLE, AL (256) 721-9090



CDS-John Blue Company

Division of Advanced Systems Technology

165 Electronics Blvd, Huntsville, AL 35824

Telephone: (256) 721-9090 - Fax (256)-721-9091 - Toll Free 1-800-253-2583

www.cds-johnblue.com

YOUR LOCAL DEALER