

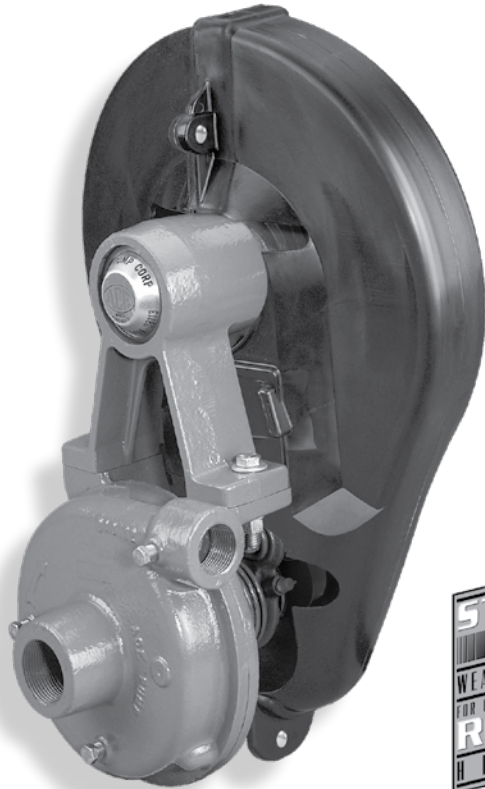

PTO Belt Driven Centrifugal Pump



PTOC SERIES

- Suction 1-1/4" - Discharge 1"
- Stainless Steel Shaft and Wear Ring
- Chemical Resistant Valox® or Optional Cast Iron Impeller
- Standard Viton® Carbon/Ceramic seal or Optional Severe Duty Silicon Carbide Mechanical Seal
- Spring loaded idler absorbs shock of PTO engagement.
- Six models available - see back page
- New BAC-15-PIN feature ensures proper alignment

Valox® is a registered trademark of GE Plastics.
 Viton® is a registered trademark of DuPont Dow Elastomers.

600 RPM PERFORMANCE CHART

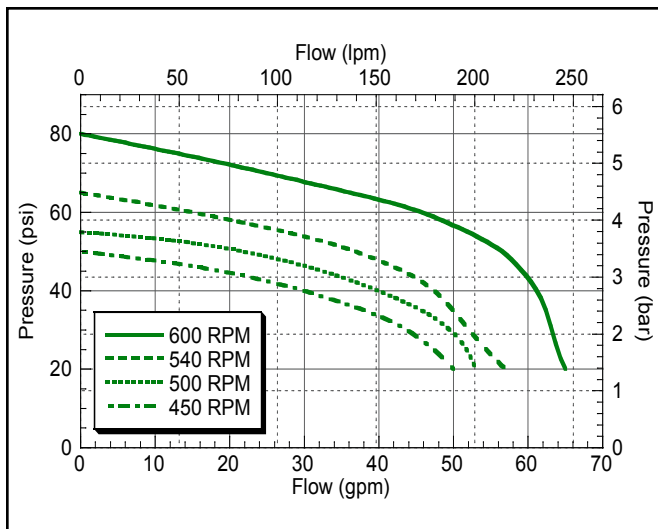

1000 RPM PERFORMANCE CHART

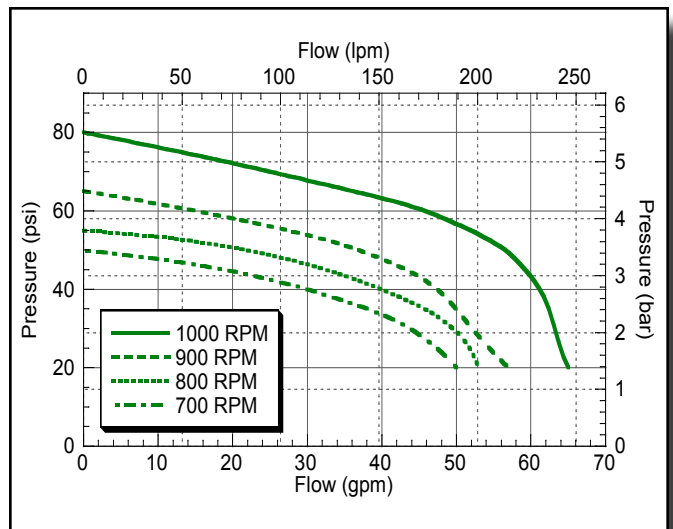

EXPLODED VIEW DRAWING

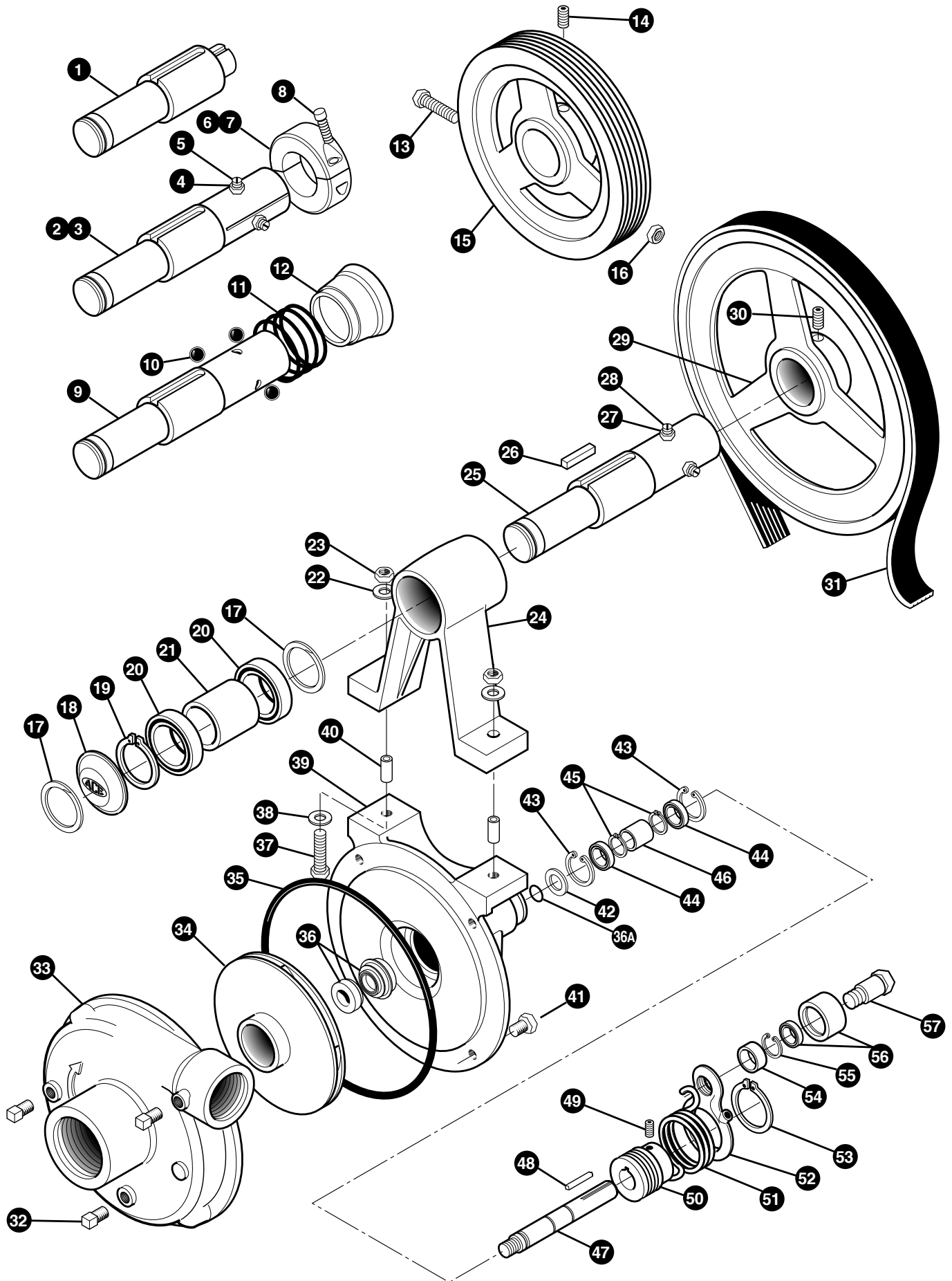

PARTS LIST

REF. #	PART #	EDP #	DESCRIPTION	REQ.
1	BAC-10-S	40190	1" Tumblerod stub drive shaft	1
2	BAC-10-175-20SP	40180	1-3/4" 20 Tooth PTO spline drive shaft, includes BAC-11-175	1
3	BAC-10-21SP	40220	1 3/8" 21 Tooth PTO spline drive shaft, includes BAC-11	1
4	40960	40960	3/8" NC jam nut	3
5	BAC-40	40940	3/8" NC slotted set screw	3
6	BAC-11-175	40236	Locking collar, split ring (for BAC-10-175-20SP shaft)	1
7	BAC-11	40235	Locking collar, split ring (for BAC-10-21SP shaft)	1
8	BAC-11-1	40237	Set screw (for BAC-11 and BAC-11-175 locking collar)	1
9	BAC-10-6SP-QC	40210	1-3/8" 6 Tooth PTO spline drive shaft for quick coupler	1
10	BAC-83-QC	41470	Ball for quick coupler	3
11	BAC-82-QC	41460	Spring for quick coupler	1
12	BAC-81-QC	41450	Ball retainer sleeve for quick coupler	1
13	41250	41250	5/16" NC x 3-1/4" hex head cap screw	1
14	41300	41300	3/8" NC x 5/8" allen head set screw	2
15	BAC-30-10-M	40750	6.375" P.D. x 2" Bore Poly-V pulley (for PTOC 1000-21SP & -B)	1
15	BAC-30-175	40745	6.375" P.D x 2-3/8" Bore Poly-V pulley (for PTOC 1000-20SP)	1
16	BAC-63	41260	5/16" NC self locking nut for tumblerod drive	1
17	BAC-34	40830	Internal snap ring, BAC-15 bearing housing	2
18	BAC-27-175	40505	Name plate (for PTOC-1000-20SP)	1
18	BAC-27-M-10	40500	Name plate (for PTOC-1000-21SP)	1
18	BAC-27-P-10	40510	Name plate (for PTOC-600)	1
19	BAC-35	40840	External snap ring, BAC-10 drive shaft	1
20	BAC-31-1	40781	Sealed ball bearing, BAC-10 drive shaft	2
21	BAC-38-1	40905	Bearing spacer, BAC-10 shaft	1
22	BAC-44	40990	3/8" Lock washer	2
23	BAC-45	41010	3/8" NC Hex nut	2
24	BAC-15	40340	PTO drive shaft bearing housing	1
24	BAC-15-B	40370	Tumblerod drive shaft bearing housing with mounting base	1
25	BAC-10-6SP	40200	1-3/8" 6 Tooth PTO spline drive shaft	1
26	BAC-51	41090	3/8" x 1/2" x 1-1/2" key, PTO drive shaft	1
27	40960	40960	3/8" NC jam nut	3
28	BAC-40	40940	3/8" NC slotted set screw	3
29	BAC-30-10	40740	10.6" P.D. x 2" bore Poly-V pulley, 10 groove (for PTOC-600)	1
30	41300	41300	3/8" NC x 5/8" allen head set screw	2
31①	BAC-28-10	40610	Poly-V Belt, 10 groove (for PTOC -600)	1
31②	BAC-28-10-M	40620	Poly-V Belt, 10 groove (for PTOC-1000)	1
32	BAC-53	41110	1/8" NPT Pipe plug	3
32	41120	41120	1/8" NPT Pipe plug, stainless steel (optional)	3
33	BAC-12	40250	Volute 1-1/4" x 1", cast iron	1
34	BAC-26-CI	40432	Impeller, cast Iron, left hand thread (optional)	1
34	BAC-26-VALOX	40430	Impeller, Valox, left hand thread	1
35①②③④	BAC-4-A	40005	"O" Ring, volute seal	1
36④	BAC-7SC	40152	Silicon carbide mechanical seal (includes 40160) (optional)	1
36①②③	BAC-7V	40151	Viton mechanical seal (includes 40160 "O" Ring)	1
36A①②③④	40160	40160	"O" ring for mechanical seal	1
37	BAC-42	40970	3/8" NC x 2" Hex head cap screw	2
38	BAC-43	40980	3/8" Flat washer	2
39	BAC-14-MIA	40290	Mounting frame, machined for idler arm	1
40	BAC-15-PIN	40799	Alignment pin	2
41	40930	40930	3/8" NC x 3/4" hex head cap screw, stainless steel (optional)	4
41	40950	40950	3/8" NC x 3/4" hex head cap screw	4
42	BAC-54	41130	Slinger	1
43	BAC-33	40810	Internal snap ring for mounting frame	2
44	BAC-37	40870	Sealed ball bearing for pump shaft	2
45	BAC-32	40790	External snap ring for driven pump shaft	2
46	BAC-32-S	40795	Spacer for pump shaft	1
47	BAC-6-SS	40070	5/8" Driven shaft, left hand course thread, stainless steel	1
48	BAC-50	41080	3/16" x 3/16" x 1-1/4" key	1
49	BAC-57	41180	5/16" NC x 5/16" allen head set screw for BAC-29-10 pulley	2
50	BAC-29-10-1.50	40680	1.5" P.D. x 5/8" bore Poly-V pulley, 10 groove	1
51	BAC-5	40030	Idler mounted torsion spring	1
52	BAC-13	40270	Idler arm	1
53	BAC-36	40850	External snap ring, BAC-13 idler arm	1
54	BAC-46	41020	5/8" Spacer	1
55	41070	41070	Retainer ring	1
56	BAC-55	41140	Idler bearing and outer roller assembly	1
57	BAC-47	41040	5/8" NC x 2 1/8" hex head idler cap screw	1
#	BAC-52	41100	1/4" cold shut, torque chain anchor	1
#	BAC-58	41190	Zerk fitting, 1/4" NPT, for idler arm	1
#	BAC-55-A	41150	Idler arm assembly (includes 52 through 57 and BAC-58)	-
#	BGKB	52610	Belt and shaft guard kit for all PTOC pumps	-
①	RK-PTOC-600	51150	Repair kit for 600 RPM models, includes belt, seal, and "O" ring	-
②	RK-PTOC-1000	51250	Repair kit for 1000 RPM, includes belt, seal, and "O" ring	-
③	RK-FMFC	52700	Repair kit for pump only, includes seal, and "O" ring	-
④	RK-FM CSC	52706	Repair kit for pump only, includes silicon carbide seal, and "O" ring	-
#	FMC-MIA	47000	Pump end only, machined to accept idler arm	-

Not shown in exploded view drawing.



PTO SHAFT OPTIONS:

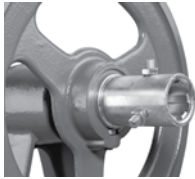

PTOC-600-6SP



PTOC-600-6SPQC



PTOC-600-B

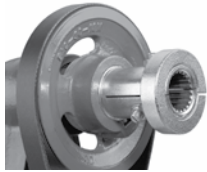

PTOC-1000-21SP

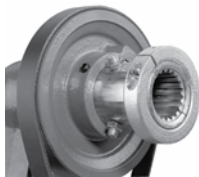

PTOC-1000-20SP



PTOC-1000-B

DIMENSIONS

